

PAP750U PRELIMINARY INFORMATION

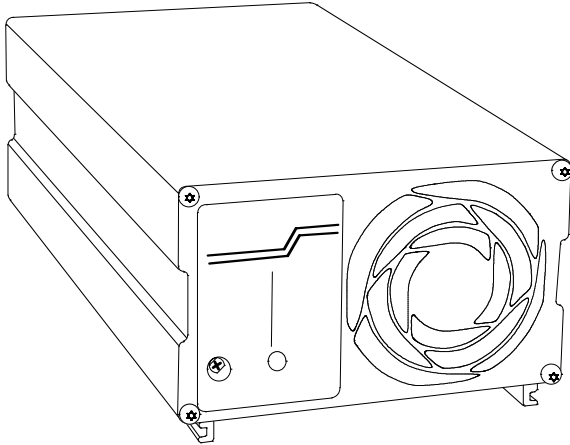

Features:

Switched mode power supply

Wide output range 0...144Vdc

Analog control by an external 0...5Vdc

Power failure alarm output

Master-slave connection

The Powerfinn PAP750U is a high power, lightweight, advanced power supply using modern switching technology. The unit can be used as a power supply, cyclic battery charger or with customized charging curves for all kind of batteries. The output voltage and output current can be adjusted from 0 to maximum value by a trimmer on the front panel, or by an optional 0-5V analog control.

Specifications

Input voltage		55...250Vac (65...110VAC reduced power, see curve p. 3)
		Input current 9 A
Power factor		>0,98 typical
Efficiency (240Vac, 10%...100% load)		84% typical
Inrush current		<30A, limited by a NTC resistor
Input fuse (inside the unit)		10A
Line regulation		±0.1%
Load regulation		±0.5%
Output setting accuracy		±0.1%
Output ripple (f>50Hz)		<50 mVrms
Hold-up time		> 5 ms
Status LED indicator		Orange: power OK
Isolation	input-chassis	1500 Vac
	input-output	3750 Vac
	output-chassis	500 Vac
Standards	safety	EN 60335-2-29:1996 + A11:97 (IEC335-2-29:2002 modified) ^{*)}
	EMC	EN 55022A
Approvals		All models CE marked
Protection class	mechanical	IP20 metal enclosure
	electrical	Class 1
Dimensions	w x h x d	220 x 112 x 73 mm
Weight		1,55 kg
Mounting		DIN-rail, wall, bench
Cooling		Temperature controlled fan
Operating temp range		-25°C...+40°C

^{*)} Note: Article 10.101 (The no-load DC output voltage shall not exceed 42,4V) is not fulfilled for chargers with a rated output voltage of more than 36V.

PAP750U PRELIMINARY INFORMATION
--

Power Supply Models

Trimmer adjustable power supplies							
Model	Input voltage range ^{*)}	Nominal output voltage	Voltage Setting range	Nominal output current	Current setting range	Max power	Installation/dimensions (width x height x depth)
PAP750U/12	55-250Vac	12Vdc	0-18Vdc	40A	0-40A	720W	Wall /bench 220x112x73
PAP750U/24	55-250Vac	24Vdc	0-36Vdc	30A	0-30A	750W	Wall /bench 220x112x73
PAP750U/36	55-250Vac	36Vdc	0-54Vdc	20A	0-20A	750W	Wall /bench 220x112x73
PAP750U/48	55-250Vac	48Vdc	0-72Vdc	15A	0-15A	750W	Wall /bench 220x112x73
PAP750U/72	55-250Vac	72Vdc	0-108Vdc	10A	0-10A	750W	Wall /bench 220x112x73
PAP750U/96	55-250Vac	96Vdc	0-144Vdc	7,5A	0-7,5A	750W	Wall /bench 220x112x73

0-5 V external control signal adjustable power supplies							
Model ^{*)}	Input voltage range ^{**)}	Nominal output voltage	Voltage Setting range	Nominal output current	Current setting range	Max power	Installation/dimensions (width x height x depth)
PAP750U/12AI	55-250Vac	12Vdc	0-18Vdc	40A	0-40A	720W	Wall /bench 220x112x73
PAP750U/24AI	55-250Vac	24Vdc	0-36Vdc	30A	0-30A	750W	Wall /bench 220x112x73
PAP750U/36AI	55-250Vac	36Vdc	0-54Vdc	20A	0-20A	750W	Wall /bench 220x112x73
PAP750U/48AI	55-250Vac	48Vdc	0-72Vdc	15A	0-15A	750W	Wall /bench 220x112x73
PAP750U/72AI	55-250Vac	72Vdc	0-108Vdc	10A	0-10A	750W	Wall /bench 220x112x73
PAP750U/96AI	55-250Vac	96Vdc	0-144Vdc	7,5A	0-7,5A	750W	Wall /bench 220x112x73

^{*)} Cable sets with modular connectors are included: 1,5 m cable for analog control and 2,5 m for temperature compensated models

^{**) Reduced power 55...200Vac or 78...200Vdc, see curves; max 600W when used with DC input}

Models with power failure output relay (24V models as type designation example)		
Model	Option description	Cable set
PAP750U/24H	Trimmer adjustable model with power failure alarm relay	1,5 m, modular connector
PAP750U/24AIH	Analog controllable model with power failure alarm relay	Analog + relay cables
PAP750U/24TH	Temperature compensated model with power failure alarm relay	Temp. comp + relay cables

Master-slave connection (24V models as type designation example)	
Master units ^{****)}	Slave units
PAP750U/24, PAP750U/24AI or PAP750U/24T	PAP750U/24S RS232 control bus in/out
Control to slave via RS232 bus	PAP750U/24SH slave unit with relay, RS-232 bus in only

^{****)} Cable set for master slave connection included in slave unit type number, 0,6 m modular connectors at both ends

^{****)} Master unit or slave with RS232 bus output cannot include the alarm relay

Customized versions on request

- Cyclic battery chargers or customized charging curves for all kind of batteries
- Sense models
- IP44 enclosures, 19" enclosures

PAP750U PRELIMINARY INFORMATION

Characteristics

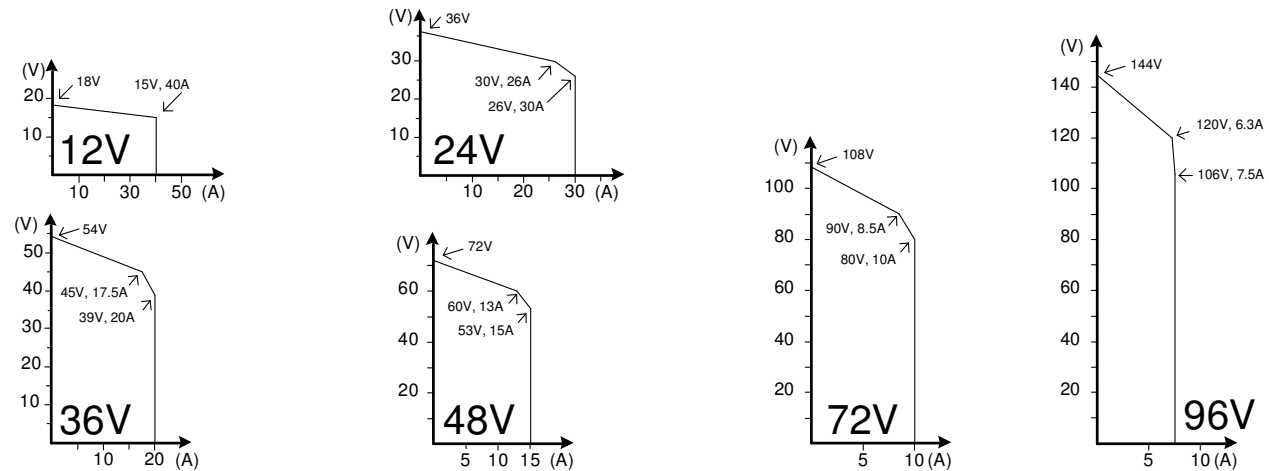

Nominal output current / voltage characteristics PAP750U

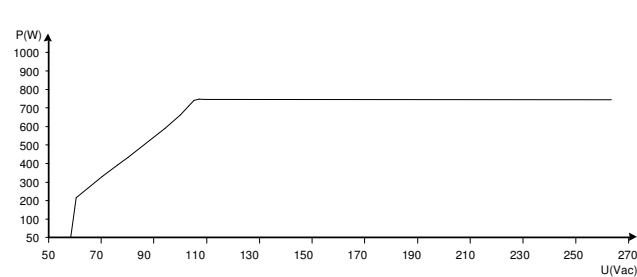

Output power / input voltage de-rating characteristic

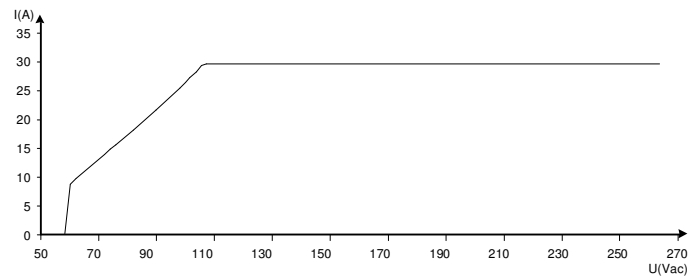

Output current / input voltage de-rating characteristic nominal output

Installation

1. The location must be dry, dust-free and indoor. The acceptable full power temperature range is $-25^{\circ}\text{C} \dots +50^{\circ}\text{C}$. Higher ambient temperature will limit the power (see curve). The power supply is not waterproof. Keep it dry and away from areas with high humidity in order to avoid the risk for electrical shock and damages to the charger.
2. The power supply can be installed horizontally or vertically. In case the power supply is mounted vertically with the cable plate downwards, the floor and everything right below the power supply must be fire-resistant. Vertical mounting is prohibited in case this condition cannot be met.
3. Leave at least 10 cm free space at both ends of the power supply to ensure sufficient ventilation.

When used as a charger, the charging process generates explosive hydrogen gas. Keep the area well ventilated Never use an open flame or equipment that produce sparks close to the power supply and battery.

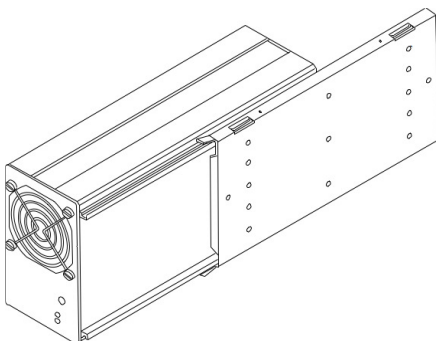

Wall mounting

Screw the assembly board to the wall using the mounting holes in the back of the board. Next, place the power supply to the assembly board and fasten it by using the small screws on the sides of the board.

PAP750U PRELIMINARY INFORMATION

Charging operation

1. Ensure that the power supply is switched off and that the environment meets the conditions as described in the previous section.
2. Connect the output cables to the load / battery terminals: + cable to the + terminal and – cable to the – terminal

Note: Do not cut the output cables. In case the cables are shortened, the output voltage is overcompensated as much as the loss of voltage drops in the cable. The overcompensation may cause voltage variations depending on the current consumption.

3. Turn the power on by turning the switch to position 1.
4. During normal power supply operation / charging process, the STATUS LED will light continuous orange.
5. To avoid sparking, turn off the power supply before disconnecting the cables.

DC Input connection

The power supply input cable is connected as follows:

- L negative or positive DC supply input
- N positive or negative DC supply input
- PE protective earth

Output voltage and current limit adjustment

Trimmer or analog control adjustable modules, type example PAP750U/24 or PAP750U/24AI:

The output voltage and output current limit of the power supply can be adjusted as follows:

- Trimmer adjustable models: with the multi-turn potentiometers accessible from the front panel.
- Analog controllable models by an external 0-5Vdc voltage. See detailed description

Both voltage and current can be adjusted from zero to the maximum value. Maximum 750W output power is available within the adjustment range.

Temperature compensated models, type example PAP750U/24T:

The power supply includes 16 pre-programmed output voltages that are set by the code switch. See the setting table for this unit. Any of these 16 different voltage settings can be taken in use and additionally be adjusted within $\pm 5\%$ using the trimmer on the front panel. See the instructions for choosing the programmed voltage and the fine-tune adjustment.

LED

An orange LED indicates a healthy power supply output voltage.

Over current protection

The output of the power supply is protected against over currents and short circuits by an automatic, self-resetting electronic current limiter.

Series/parallel connection

Parallel operation: No restrictions, passive load sharing
Series operation: Up to 500V total voltage

Warning

Dangerous voltages, capable of causing death are present in the power supply. Do not remove the cover. There are no operator serviceable parts inside the unit. Refer servicing to qualified service personnel only.

PAP750U PRELIMINARY INFORMATION

Feature selection table

	Trimmer	Analog	Relay	Bus out	Bus in	Temp	Sensor	Code switch
Trimmer adjustment	●		●	●			●	
Analog control (isolated)		●	●	●			●	
Alarm relay	●	●	●		●	●	●	●
BusOut (RS-232 control to slave)	●	●		●	●	●	●	●
BusIn			●	●	●	●	●	●
Temp. compensation			●	●	●	●	●	●
Sensor	●	●	●	●	●	●	●	●
Customized charging algorithm chargers with code switch			●	●	●	●	●	●

Modular connectors

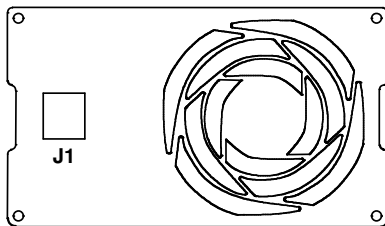

Front panel

J1 Analog input 0...5Vdc

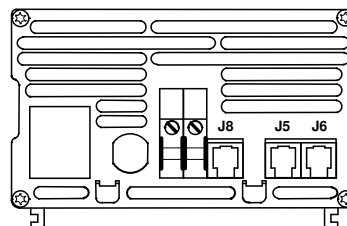

Rear panel

- J8 RS-232 bus output, master slave
Alternatively power failure alarm relay
- J5 Temperature compensation (Temp.comp models);
Voltage drop compensation option
Alternatively RS-232 bus input master-slave
- J6 Optional external LED

Alarm relay models

On models with an alarm relay, the alarm relay output indicates whether the output voltage is healthy or not. The alarm signal is activated in case of an AC failure or charger failure. Both normally closed signals and normally open contacts are available.

Pin configuration, modular connector J8 with alarm relay option

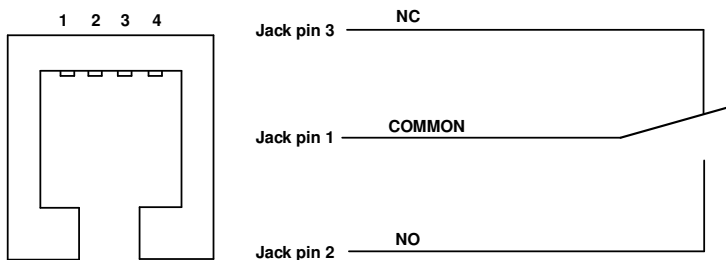

Common is connected to NC when the power is switched off.
Common is connected to NO when the power is switched on.

Cable

Black = common
Red = NO
Green = NC

Relay

Isolation:
Output to case: 500V
Output to gnd: 120V

Technical data:
1A@24Vdc
0,5A@120Vac

PAP750U PRELIMINARY INFORMATION

Analog control and master–slave connection

The optional analog control allows full control of the output current and voltages and it provides the measured values for both of these. A +5V supply power is available for the supply of the control logic. The analog input has an isolation value of 500 V towards the input and output of the power supply.

The master–slave bus cables are connected from the master unit to the slave units as shown in the picture.

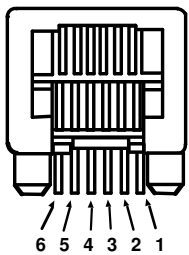
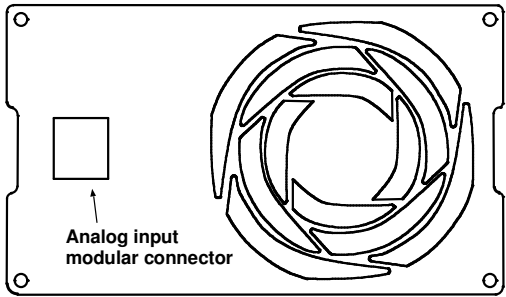

- Pin configuration
1. Ground
 2. Current control input
 3. Voltage control input
 4. Measured current value
 5. Measured voltage value
 6. +5V (max 20mA) output

Pin configuration of the modular connector J1
The analog control card is connected via an AMP Modular 6 connector.

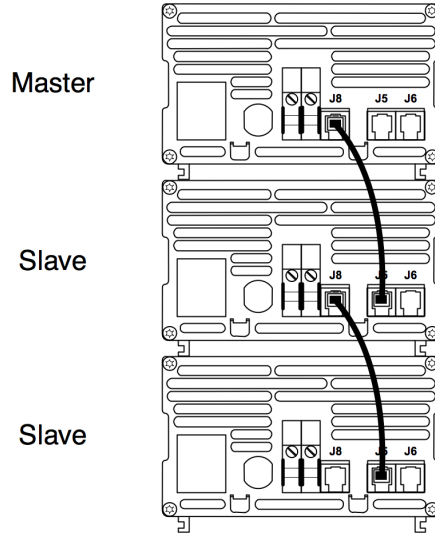

Master–slave connections. The first unit must be used as master unit. The number of slaves is unlimited.

Controlling the analog card

All control voltages must be between 0 and +5V, Higher voltages are not allowed. The control logic is positive, so that a +5V control voltage gives a maximum value from the power supply, while 0V means minimum output. As soon as the control connector is unplugged from the modular connector, the power supply is reset to the minimum output values.

The measured values can be read from the measurement signals. The measured values are scaled equal to the target values. If the power supply is set to the voltage reference, the measured value must be equal to the target. The same counts for the current control and its measured value. Measured signals (both together) can be loaded with max 20mA; otherwise proper operation cannot be guaranteed.

The modular connector is isolated from the input, output and enclosure of the power supply. This enables the possibility to parallel or series connect several power supplies maintaining equal voltages. The number of connected devices is not limited. The 500V insulation voltage may, however, not be exceeded. This manual cannot be applied in case the connector of the analog card differs from a modular connector (9-pin D-connector). In that case it is an incompatible analog controlled power supply.

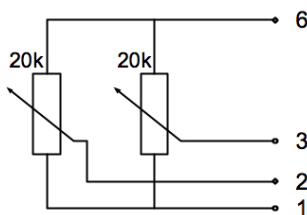

Connecting example using the internal +5Vdc supply and external potentiometers.

The +5V can be used as a supply for external circuits. The circuit given to the left, lets the power supply operate as a potentiometer controlled device. It is important to keep in mind that the +5V output may not be loaded more than 20mA, otherwise proper operation cannot be guaranteed.